

THD 120 x 120 x 38 MM SERIES

■ DIMENSIONS DRAWING

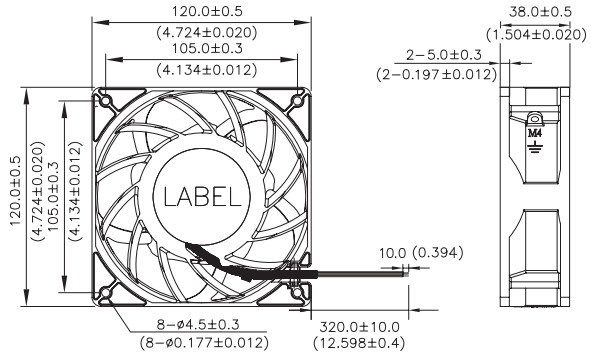
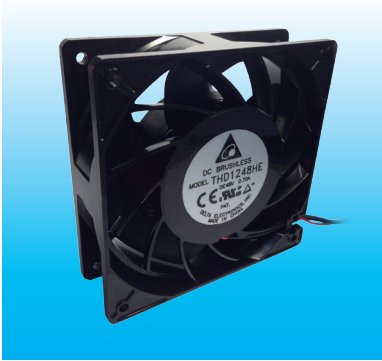

UNIT: MM(INCH)

- * Bearing Type
Ball Bearings
- * Material
Impeller : Plastic (UL 94V-0)
Frame : Die-cast Aluminum
- * Lead Wires :
UL 1430 AWG#22 OR Equivalent
Red Wire Positive(+)
Black Wire Negative(-)
Yellow Wire Speed Control(PWM)
Blue Wire(F00)
- * Weight : 475g (16.76 OZ)

■ P & Q CURVE (AT RATED VOLTAGE)

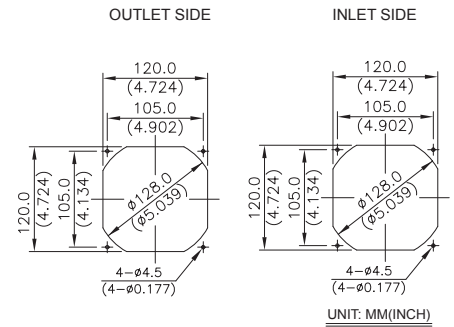
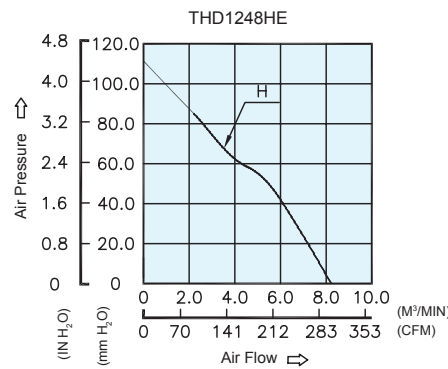

UNIT: MM(INCH)



MODEL		Rated Voltage	Operating Voltage Range	Rated Current	Rated Input Power	Speed	Maximum Air Flow		Maximum Air Pressure		Noise
PART NO.	FUNCTION	VDC	AC	Amp	Watt	R.P.M.	m ³ /min	CFM	mmH ₂ O	IN H ₂ O	dB-A
THD1248HE	PWM/F00	48	32.0 to 59.0	2.20	105.82	10900	8.122	287.00	111.76	4.400	75.0

- * Function type is optional.
- * The max. air flow and the speed are measured in free air ; max. air pressure is measured at zero air flow.
- * Noise is measured in anechoic chamber in free air, one meter from intake side.
- * All readings are typical values at rated voltage.
- * Specifications are subject to change without notice.